

(12) INTERNATIONAL APPLICATION PUBLISHED UNDER THE PATENT COOPERATION TREATY (PCT)

(19) World Intellectual Property Organization
International Bureau



(43) International Publication Date
2 May 2002 (02.05.2002)

PCT

(10) International Publication Number
WO 02/34340 A1

- (51) International Patent Classification⁷: A63B 59/00, 71/14
- (21) International Application Number: PCT/AU01/01386
- (22) International Filing Date: 29 October 2001 (29.10.2001)
- (25) Filing Language: English
- (26) Publication Language: English
- (30) Priority Data:
0026267.5 27 October 2000 (27.10.2000) GB
0110966.9 4 May 2001 (04.05.2001) GB
- (71) Applicant and
(72) Inventor: WATSON, Ken [AU/AU]; 65 Circe Circle, Dalkeith, WA 6009 (AU).
- (71) Applicant and
(72) Inventor (for US only): MCSHERRY, Elma [GB/GB]; 65 Circe Circle, Dalkeith, WA 6009 (AU):
- (74) Agent: WRAY & ASSOCIATES; 239 Adelaide Terrace, Perth, W.A. 6000 (AU).
- (81) Designated States (national): AE, AG, AL, AM, AT, AU, AZ, BA, BB, BG, BR, BY, BZ, CA, CH, CN, CO, CR, CU, CZ, DE, DK, DM, DZ, EC, EE, ES, FI, GB, GD, GE, GH, GM, HR, HU, ID, IL, IN, IS, JP, KE, KG, KP, KR, KZ, LC, LK, LR, LS, LT, LU, LV, MA, MD, MG, MK, MN, MW, MX, MZ, NO, NZ, OM, PH, PL, PT, RO, RU, SD, SE, SG, SI, SK, SL, TJ, TM, TR, TT, TZ, UA, UG, US, UZ, VN, YU, ZA, ZW.
- (84) Designated States (regional): ARIPO patent (GH, GM, KE, LS, MW, MZ, SD, SL, SZ, TZ, UG, ZW), Eurasian patent (AM, AZ, BY, KG, KZ, MD, RU, TJ, TM), European patent (AT, BE, CH, CY, DE, DK, ES, FI, FR, GB, GR, IE, IT, LU, MC, NL, PT, SE, TR), OAPI patent (BF, BJ, CF, CG, CI, CM, GA, GN, GQ, GW, ML, MR, NE, SN, TD, TG).
- Published:
— with international search report
- For two-letter codes and other abbreviations, refer to the "Guidance Notes on Codes and Abbreviations" appearing at the beginning of each regular issue of the PCT Gazette.

(54) Title: BALL GAME DEVICE

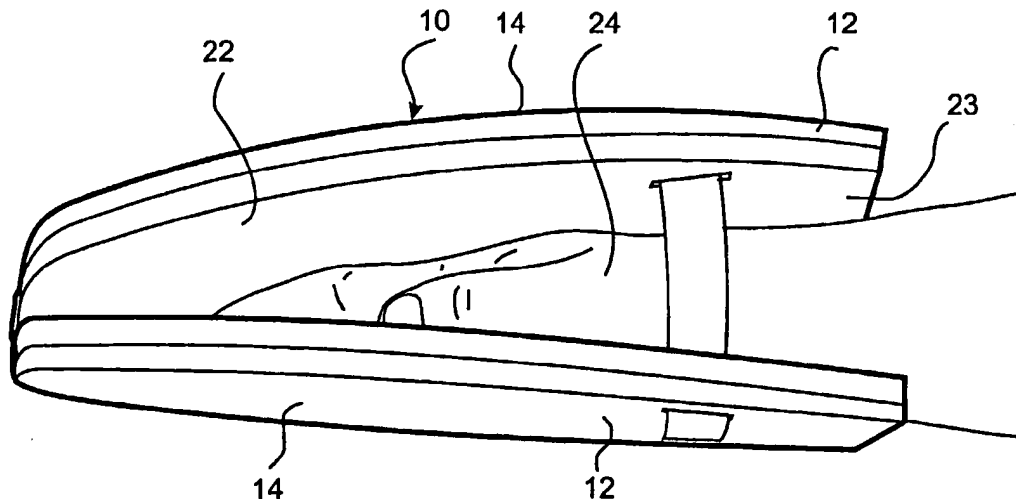

(57) Abstract: A ball game device comprising a body (10) adapted to receive a hand (24) of a user (26), the body (10) presenting two hitting surfaces (14) for hitting a ball (20). The body (10) comprises two panels (12) with a cavity (22) therebetween for receiving the hand (24) through an opening (23). The device may also be supplied in kit form.

WO 02/34340 A1

"Ball Game Device"

Field of the Invention

The present invention relates to a ball game device used particularly, but not exclusively, for teaching and learning general co-ordination for racquet sports
5 without the need to use a conventional handled racquet.

The device can also be used as leisure equipment or as a toy, having a strong "fun" element. In addition, the device can be used as a physical education training aid (for example, in schools) or as a piece of games apparatus for the disabled or those in rehabilitation.

10 Background Art

For a young child to learn a racquet sport, the first obstacle to overcome is that of general co-ordination. Holding a racquet and making it connect with a ball is a difficult skill to learn. A child learning to do this needs to learn in a way that is not too advanced, which could lead to frustration, and also in a way that will be
15 stimulating so that the child does not get bored.

At present, equipment for teaching children and allowing them to learn elementary co-ordination and racquet skills includes miniature racquets, most commonly made of plastic and provided with soft sponge balls. These racquets feature short handles, which facilitate easier control of the ball than in an adult-size racquet
20 because the racquet head is nearer the hand of the user in the case of miniature racquets. Miniature racquets are also lighter than adult-size racquets, thus making it easier for children to use them.

Another option on the market is an arrangement where two discs are supplied with a furry ball. One side of the discs is covered in VELCRO or "suckers" to
25 which the ball adheres, and the other side is supplied with a strap for holding the disc to a hand on its palm side. This device helps a child improve basic catching skills.

However, the design of these currently available learning aids have some shortcomings. For example, a child still has to learn how to hold a miniature racquet correctly whilst at the same time developing the skills of hand-eye coordination. It can be difficult to learn these skills simultaneously.

- 5 It is an aim of the present invention to at least partly improve upon some of the present methods of teaching and learning general co-ordination for racquet sports.

Disclosure of the Invention

10 The present invention provides a ball game device comprising a body adapted to receive a hand of a user, the body presenting a first hitting surface for hitting a ball. The body preferably comprises a second hitting surface opposed to the first hitting surface.

15 The or each hitting surface is preferably defined by a panel. The panel typically comprises a first panel defining the first hitting surface and a second panel defining the second hitting surface. The first and second panels are preferably planar.

20 The panels are preferably conformed to the shape of a racquet head so as to simulate a racquet and thereby assist in teaching of a racquet sport. The two panels may be differently coloured or marked to facilitate learning of forehand and backhand strokes.

Furthermore, a cavity is preferably defined within the body to receive the hand. The cavity may be configured as a mitt or a glove and the cavity is preferably dimensioned so that a wrist of the user is positioned between the panels.

25 The or each panel typically comprises an inner face and an outer face, the or each outer face presenting the hitting surface to hit the ball.

- 3 -

Further, the or each panel usually comprises an inner layer and an outer layer, the outer layer comprising the outer face and the inner layer comprising the inner face. The outer layer is preferably comprised of a rigid material for striking the ball and the inner layer is preferably comprised of a flexible material to conform to
5 the shape of the hand. Conveniently, the rigid material may be cardboard and/or plastic such as moulded plastic. The flexible material may be foam.

Preferably, the first panel and the second panel are connected in spaced apart relationship to define the cavity therebetween.

The device may further comprise connection means for connecting the two panels
10 together and the connection means may be adapted to maintain the panels in spaced apart relationship.

The connection means is preferably positioned on the inner face of the first panel and may be adapted for connection to the second panel in an arrangement to allow an opening in the cavity between the first and second panels for insertion of
15 the hand. In an alternative arrangement, the connection means may be positioned on both the first and second panels to allow joining of the panels in a suitable way.

In some arrangements, the connection means conveniently comprises a plurality of spacers positioned around the periphery of the inner face of the first panel.

20 Where convenient, the connection means may comprise a snap-fit connector.

In one arrangement, the connection means is preferably hinged to the inner face of the or each panel for pivotal movement between an operative and a stored condition.

The inner face of the panels may further comprise a flange of rigid material
25 bounding the inner layer to present a solid surface on which to attach the connection means and to assist in retaining the inner layer in a secure

- 4 -

arrangement. Conveniently the flange may be connected to the outer layer which is also formed of rigid material.

The connection means preferably comprises a set of first connection elements on the first panel and a set of second connection elements on the second panel, the
5 first and second connection elements preferably being adapted to be connected together to connect the first and second panels together in spaced apart relationship to define the cavity.

The first connection elements may be pivoted between operative and stored conditions and the second connection elements can be similarly pivoted. Pivoting
10 of the connection elements to the stored condition allows the connection elements to lay flat in approximate parallel arrangement with the panels for ease of storage.

The spacers may be dimensioned so that a first end of the first panel is maintained at a first distance from a first end of the second panel and so that a second end of the first panel is maintained at a second distance from a second
15 end of the second panel, the second distance being greater than the first distance. This formation creates a tapering effect which allows the device to conform to the shape of a hand.

The opening between the first and second panels is positioned at the second ends of the first and second panels so that the device tapers towards the first
20 ends of the first and second panels.

The or each outer face of the panels may be bounded by a raised periphery thus simulating a racquet head.

The connection means may comprise hinge means and a means for drawing the panels together about the hinge. Typically the latter means comprises an
25 adjustable strap system such as an elastic strap. In this form of the invention, the elastic strap allows the panels to move apart to a distance appropriate to accommodate the size of the hand of the user. In this way, one form of the device may accommodate hands of differing sizes.

The device may be supplied in kit form.

The kit typically comprises:

material for forming the panels and spacers;

a template for cutting out the panels and spacers; and

5 instructions for assembly of the device.

The kit may further comprise instructions for games to be played with the device. Alternatively, instructions may be provided as a separate item from the kit.

The instructions may be in book, CD-rom, video or internet-based form.

The kit may also comprise a ball or balls for use with the device.

10 The present invention also provides instructions for games to be played with a ball game device comprising a body adapted to receive a hand of a user, the body presenting a first hitting surface for hitting a ball. The body may further comprise a second hitting surface opposed to the first hitting surface.

The present invention also provides a ball game device comprising a substantially
15 racquet-head shaped device that fits over a user's hand in a glove-like manner, thus providing a racquet that moves directly with the hand, ensuring that the user can instinctively hit the ball.

The device may comprise two panels which are conjoined at a first end by a hinge and at a second end by an elastic strap, the construction allowing the user to slide
20 a hand (in a glove-like manner) between the two panels.

The device is ideally light-weight and safe for a child to use. To assist in safety aspects, the device typically has rounded edges and not sharp edges.

In one form of the invention, the kit may comprise:

5 30 (5mm thickness) cardboard pieces, including 2 rectangular pieces of width 22cm and length 30cm (from which will be cut the panels of the device), and 28 strips of width 2cm and length 6cm (the spacers of the device);

an instruction booklet for assembly of the device;

a template for cutting out the panels of the device and for positioning of the spacers; and

instructions for games to be played with the device.

10 The ball game device of the invention provides an easy method for a child to develop the hand-eye coordination and agility required for racquet sports. The learning of the proper racquet grip is delayed due to the fact that the device does not comprise a handle. The beginner can master the hand-eye coordination required for a racquet sport using the device of the invention before at a later
15 stage learning the process of the racquet grip.

Hand-eye coordination skills are easier to develop using the device relative to miniature or adult-sized racquets. This is partly due to the fact that there is a reduced distance from the eyes to the point of impact with the ball in the case of the device relative to miniature or adult-sized racquets. There is also a greatly
20 reduced distance from the point of application of the force and the impact point with the ball in the case of the device of the invention as compared to miniature or adult-sized racquets.

A further benefit of the invention is that the panels of the device extend over the wrist of the user which encourages proper use of the arm in a swing movement
25 and also encourages proper orientation and movement of the wrist.

Brief Description of the Drawings

The invention will be better understood by reference to the following description of several specific embodiments as shown in the accompanying drawings, in which:

5 Figure 1 shows the supplied pieces of card of a first embodiment of the present invention;

Figure 2 is a plan view of the first embodiment of the present invention showing how the spacers are arranged on a first panel of the device;

Figure 3 shows a side view of the device of the first embodiment of the present invention;

10 Figures 4a, 4b, 4c and 4d show a child playing in various ways with the device of the first embodiment;

Figure 5 shows the device of a second embodiment of the present invention in the closed position, as viewed from one end;

Figure 6 shows the device of Figure 5 as viewed from the other end;

15 Figure 7 shows the device of Figure 5 in a fully opened position prior to having an elastic strap attached;

Figures 8a and 8b show the device of Figure 5 in a partially opened position prior to having the elastic strap attached;

20 Figures 9a and 9b show the device of Figure 8a and 8b with the elastic strap in the process of being attached;

Figures 10a and 10b show the device of Figure 5 in use, in place over a hand of a user;

Figure 11 shows a perspective view of a first panel of the device of a third embodiment of the present invention showing the inner face of the device prior to attachment of the connection means;

5 Figure 12 shows a perspective view of the first panel of the device of Figure 11 showing the outer face of the device;

Figure 13 shows a perspective view of the device of Figure 11 after positioning of the connection means;

Figure 14 shows a perspective view of the device of the third embodiment showing the first and second panels connected together ready for use;

10 Figure 15 shows a cross-sectional view through the panel of the device of Figure 11 along line 15-15;

Figure 16a shows a cross-sectional view through the first panel of Figure 13 along line 16-16 together with a cross-sectional view through a second corresponding panel;

15 Figure 16b shows a cross-sectional view when the first and second panels of 16a are connected together for use of the device;

Figure 17 shows a perspective view of a first panel of the device of a fourth embodiment of the present invention showing the connection means pivoted to an operative condition;

20 Figure 18 shows a cross-sectional view of the device of the fourth embodiment of the present invention through the panel of the device of Figure 17 along line 18-18;

25 Figure 19a shows a cross-sectional view of the device through the first panel of Figure 17 along line 19-19 together with a cross-sectional view through a second corresponding panel, showing the connection elements pivoted to a stored condition;

Figure 19b shows a cross-sectional view of the device of Figure 19a showing the connection elements pivoted to an operative condition;

5 Figure 20 shows a cross-sectional view of the device of Figure 19b showing the two panels joined together by means of the connection elements for use of the device;

Figure 21 shows a cross-sectional view of a device of the invention according to a fifth embodiment; and

Figure 22 shows a cross-sectional view of a device of the invention according to a sixth embodiment.

10 **Best Mode(s) for Carrying out the Invention**

Referring now to the drawings, the device of the invention comprises a body generally shown by numeral 10. The body comprises two panels 12 which present hitting surfaces 14 for striking a ball 20. A cavity 22 is present between the panels 12 for receiving a hand 24 of a user 26 by means of an opening 23.

15 Each panel is formed of an inner layer 28 and an outer layer 30. The panels further comprise an inner face 32 and an outer face 34.

Connection means 35 are provided to join the two panels 12 together which are in the form of spacers 36 in the first embodiment. The connection means can also be in the form of first connection elements 38 and second connection elements 40
20 as shown in the case of the third to sixth embodiments.

Referring to the first embodiment illustrated in Figures 1 to 4, two panels 12 of appropriate shape are cut out of the cardboard piece 15. Spacers 36 in the form of a number of cardboard pieces are attached to the panels 12 using sticky tape in an arrangement as shown in Figure 2. This arrangement allows one end 11 of the
25 device to be open for insertion of a hand 24 through the opening 23 whilst the other end 13 is partly closed off by the spacers 36.

- 10 -

As can be seen in Figure 3, varying numbers of cardboard pieces forming the spacers 36 can be used to adjust the spacing between the panels 12 to accommodate hands of varying sizes. For example, as seen in Figures 2 and 3, four spacers 36 are positioned at A, five spacers 36 are positioned at B and six
5 spacers 36 are positioned at C.

Fewer spacers 36 are positioned at first ends 54 of the panels 12 than at second ends 56 of the panels 12 so that the body 10 tapers towards the first ends 54 of the panels. This results in the cavity 22 being wider at the opening 23 of the device than at the front or first end. Thus distance b is greater than distance a in
10 Figure 3. This tapering allows for accommodation of the hand 24 since the tapering mimics the shape of the hand.

The device of the first embodiment is provided in an unassembled, kit form comprising cardboard 15 and cardboard spacers 36. Instructions are provided as to how to assemble the device together with a template for cutting out the panels
15 12. The kit also includes an instruction booklet describing various games which may be played with the device.

Construction of the device of the first embodiment from cardboard provides a cheap, easy-to-use device that can be readily produced on a large scale, for example for use by schools, racquet sport coaching organisations, recreation
20 centres and other similarly interested bodies. The assembly of the device can also be used as an art and craft project following which children can use the assembled device for play.

Figures 4a to 4d show a user 26 using the device of the first embodiment. As can be seen, the device can be used for a forehand movement (Figure 4c) and a
25 backhand movement (Figure 4d). The device can also be used to practice upward hitting of the ball 20 on either of the two panels 12 by turning of the hand to present one of the two striking faces 14 to the ball as appropriate as shown in Figures 4a and 4b. Drawings such as Figures 4a to 4d together with additional games are included in an instruction booklet relating to the device.

- 11 -

The second embodiment as shown in Figures 5 to 10 comprises a body 10 formed of two substantially identical panels 12 which conform to the shape of a racquet head. Each panel 12 is formed of an inner layer 28 and an outer layer 30. The inner layer 28 is formed of foam which deforms as necessary to comfortably
5 accommodate the hand 24. The outer layer 30 is formed of corrugated cardboard 20 to provide a firm surface for hitting a ball. As can be seen in the Figures, the outer layer 30 presents a hitting surface 14 which is substantially planar and resembles a racquet face for striking a ball.

The hitting surface is decorative as shown in Figures 5 and 6 (but omitted from
10 Figures 7 to 10).

Since a main purpose of the device is as an aid in the teaching of racquet sports, the shape and size of the panels 12 is similar to that of a standard racquet which is truncated at the lower end. In other variations, the panels 12 can be of any convenient shape and size, including in particular the shape and size of various
15 types of squash or tennis racquets or the blade of a table tennis bat.

The device of the second embodiment further comprises at one end a hinge 46 to connect the two panels 12 to each other. The hinge 46 is in the form of cardboard and flexible tape. At the other end of the device an elastic strap 48 is provided which passes through a pair of apertures 50 on each panel 12 to provide a means
20 for drawing the panels together about the hinge 46. Figures 7 and 8 show the device prior to inserting the elastic strap 48 through the apertures 50 and Figure 9 shows the elastic strap 48 being passed through the apertures 50 prior to the ends thereof being secured to form the device ready for use.

As can be seen in Figures 10a and 10b, the hand 24 is passed between the
25 panels 12 by easing the elastic strap 48 so as to move the panels 12 away from each other to form the cavity 22. As can be noted, the panels 12 extend over the wrist portion of the hand 24 of the user which provides the benefits as outlined above.

- 12 -

Due to the adjustment of the spacing between the two panels 12 by means of the elastic strap 48, the device of the second embodiment can readily accommodate all sizes and shapes of hands.

The device of the third embodiment comprises an outer frame of rigid plastic with
5 a flange 44 bounding the inner layer 28 and a raised periphery 42 bounding the outer layer 30. The flange 44 serves the purpose of providing a solid surface on which the connection means 35 can be attached. Furthermore, the flange 44 serves the purpose of retaining the foam which forms the major portion of the inner layer 28.

10 As can be seen in Figures 16a and 16b, the connection means 35 comprises a set of first connection elements 38 and a set of second connection elements 40 which fit together in the device to be used as shown in Figure 16b. The first and second connection elements are connected to the flange 44 at hinge point 37. This allows the first and second connection elements to be folded parallel to the
15 panel for convenient storage. When the device is to be used, the first and second connection elements are raised about the hinge point 37 and connected together to form the device to be used as shown in Figure 16b.

The device of the third embodiment also consists of two panels 12 which are connected together by means of the connection means 35. The connection
20 means 35 may be height-adjustable so that the spacing between the two panels of the device may be adjusted to accommodate the appropriate hand size.

The first connection elements 38 and the second connection elements 40 are snap-fit connectors, the first elements being of male configuration and the second being of female configuration. In an alternative arrangement, the first connection
25 elements may be a combination of male and female configured elements to correspond with matching male and female configured second connection elements.

The device according to the fourth embodiment is similar in many respects to that of the third embodiment. However the device of the fourth embodiment does not

comprise a flange 44 as in the case of the third embodiment but comprises a wall 45 on which are positioned the connection elements 35. The device of the fourth embodiment is also provided with first connection elements 38 and second connection elements 40 which fit together in a snap-fit arrangement as shown in
5 Figures 19a, 19b and 20.

The relative thicknesses of the inner layer and the outer layer may be varied so as to vary the overall weight of the device as shown in the fifth and sixth embodiments. As shown in Figure 21, the outer layer 30 is made of reduced thickness and the inner layer 28 is made of increased thickness relative to the
10 embodiment shown in Figure 20. Therefore, given that the outer layer 30 is provided of rigid plastic and the inner layer is of foam, the overall weight of the device shown in Figure 21 will be less than the weight of the corresponding embodiment shown in Figure 20. In another variation as shown in Figure 22,
15 portions of the outer layer 30 adjacent the connection elements 38 and 40 in the areas marked 52 have been reduced in size thereby reducing the overall weight of the device compared with the embodiment shown in Figure 20.

The embodiments disclosed herein are provided with two hitting surfaces but it should be appreciated that the device may be provided with only one hitting surface, for example for practising only forehand or backhand strokes.

20 Modifications and improvements may be made to the foregoing without departing from the scope of the present invention. Furthermore, it should be appreciated that the scope of the invention is not limited to the scope of the embodiments described.

Throughout the specification, unless the context requires otherwise, the word
25 "comprise" or variations such as "comprises" or "comprising", will be understood to imply the inclusion of a stated integer or group of integers but not the exclusion of any other integer or group of integers.

The Claims Defining the Invention are as Follows

1. A ball game device comprising a body adapted to receive a hand of a user, the body presenting a first hitting surface for hitting a ball.
2. A ball game device according to claim 1 wherein the body comprises a
5 second hitting surface opposed to the first hitting surface.
3. A ball game device according to claim 1 or claim 2 wherein the or each hitting surface is defined by a panel.
4. A ball game device according to claim 3 wherein the panel comprises a first
10 panel defining the first hitting surface and wherein there is further provided a second panel defining the second hitting surface.
5. A ball game device according to claim 3 or claim 4 wherein the or each panel is substantially planar.
6. A ball game device according to any one of claims 3 to 5 wherein the or each
panel is conformed to the shape of a racquet head.
- 15 7. A ball game device according to any one of the preceding claims wherein a cavity is defined within the body to receive the hand.
8. A ball game device according to claim 7 wherein the cavity is configured as a mitt or a glove.
9. A ball game device according to claim 7 or claim 8 wherein the cavity is
20 dimensioned so that a wrist of the user is positioned between the panels.
10. A ball game device according to any one of claims 3 to 9 wherein the or each panel comprises an inner face and an outer face, and wherein the or each outer face presents the hitting surface to hit the ball.

- 15 -

11. A ball game device according to any one of claims 3 to 10 wherein the or each panel comprises an inner layer and an outer layer, the outer layer comprising the outer face and the inner layer comprising the inner face.
12. A ball game device according to claim 11 wherein the outer layer is
5 comprised of a rigid material and the inner layer is comprised of a flexible material.
13. A ball game device according to claim 12 wherein the rigid material is cardboard and the flexible material is foam.
14. A ball game device according to claim 12 wherein the rigid material is
10 moulded plastic and the flexible material is foam.
15. A ball game device according to any one of claims 4 to 14 wherein the first panel and the second panel are connected in spaced apart relationship to define the cavity therebetween.
16. A ball game device according to any one of claims 4 to 15 further comprising
15 connection means for connecting the two panels together.
17. A ball game device according to claim 16 wherein the connection means is adapted to maintain the panels in spaced apart relationship.
18. A ball game device according to claim 16 or 17 wherein the connection
20 means is positioned on the inner face of the first panel and is adapted for connection to the second panel in an arrangement to allow an opening in the cavity between the first and second panels for insertion of the hand.
19. A ball game device according to any one of claims 16 to 18 wherein the connection means comprises a plurality of spacers positioned around the periphery of the inner face of the first panel.
- 25 20. A ball game device according to any one of claims 16 to 19 wherein the connection means comprises a snap-fit connector.

- 16 -

21. A ball game device according to any one of claims 16 to 20 wherein the connection means is hinged to the inner face of the or each panel for pivotal movement between an operative and a stored condition.
- 5 22. A ball game device according to any one of claims 16 to 21 wherein the inner face further comprises a flange of rigid material to present a solid surface on which to attach the connection means.
- 10 23. A ball game device according to any one of claims 16 to 22 wherein the connection means comprises a set of first connection elements on the first panel and a set of second connection elements on the second panel, the first and second connection elements being adapted to be connected together to connect the first and second panels together in spaced apart relationship to define the cavity.
- 15 24. A ball game device according to claim 23 wherein the first connection elements can be pivoted between operative and stored conditions and the second connection elements can be similarly pivoted.
- 20 25. A ball game device according to any one of claims 19 to 24 wherein the spacers are dimensioned so that a first end of the first panel is maintained at a first distance from a first end of the second panel and so that a second end of the first panel is maintained at a second distance from a second end of the second panel, the second distance being greater than the first distance.
26. A ball game device according to claim 25 wherein the opening between the first and second panels is positioned at the second ends of the first and second panels so that the device tapers towards the first ends of the first and second panels.
- 25 27. A ball game device according to any one of claims 10 to 26 wherein the or each outer face is bounded by a raised periphery.

- 17 -

28. A ball game device according to any one of claims 16 to 27 wherein the connection means comprises hinge means and a means for drawing the panels together about the hinge.
29. A ball game device according to claim 28 wherein the means comprises an
5 adjustable strap system.
30. A ball game device according to any one of the preceding claims wherein the device is supplied as a kit.
31. A ball game device according to claim 30 as dependent on claims 19 to 29 wherein the kit comprises:
- 10 material for forming the panels and spacers;
- a template for cutting out the panels and spacers; and
- instructions for assembly of the device.
32. A ball game device according to claim 31 wherein the kit further comprises instructions for games to be played with the device.
- 15 33. A ball game device according to claim 31 or claim 32 wherein the kit further comprises a ball or balls for use with the device.
34. Instructions for games to be played with a ball game device comprising a body adapted to receive a hand of a user, the body presenting a first hitting surface for hitting a ball.
- 20 35. Instructions for games to be played with a device according to claim 34 wherein the body further comprises a second hitting surface opposed to the first hitting surface.
36. Instructions for games to be played with a device according to claims 34 or 35 wherein the instructions are in book, CD-rom, video or internet based form.

- 18 -

37. A ball game device comprising a substantially racquet-head shaped device that fits over a user's hand in a glove-like manner, thus providing a racquet that moves directly with the hand, ensuring that the user can instinctively hit the ball.
- 5 38. A ball game device according to claim 37 wherein the device comprises two panels which are conjoined at a first end by a hinge and at a second end by an elastic strap, the construction allowing the user to slide a hand (in a glove-like manner) between the two panels.
- 10 39. A ball game device according to claim 37 or 38 wherein the device is supplied in a kit form, the kit comprising:
- 30 (5mm thickness) cardboard pieces, including 2 rectangular pieces of width 22cm and length 30cm (from which will be cut the panels of the device), and 28 strips of width 2cm and length 6cm (the spacers of the device);
- 15 an instruction booklet for assembly of the device;
- a template for cutting out the panels of the device; and
- instructions for games to be played with the device.
40. A ball game device substantially as herein described with reference to the accompanying drawings.
- 20 41. Instructions for games to be played with a ball game device substantially as herein described with reference to the accompanying drawings.

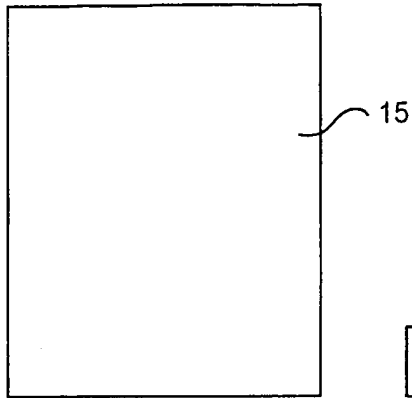

Fig. 1

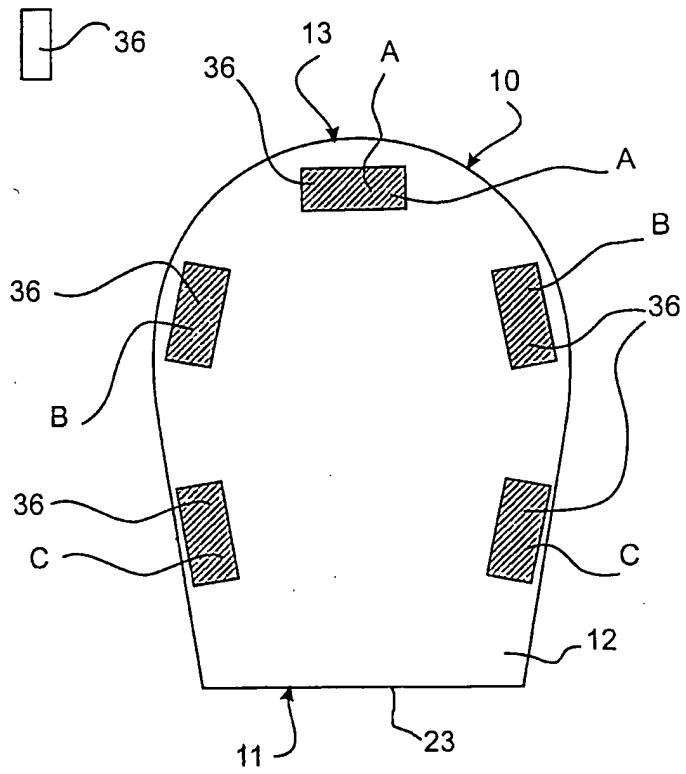

Fig. 2

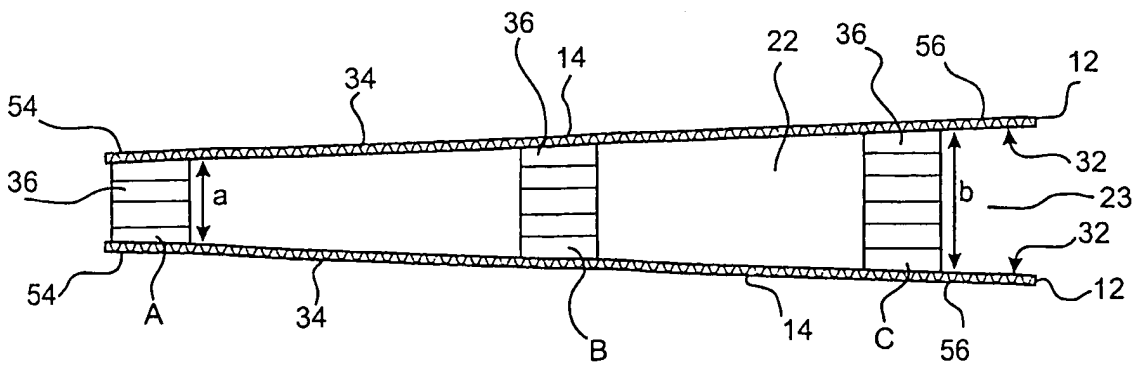

Fig. 3

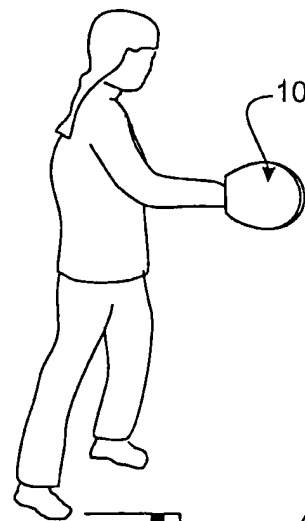
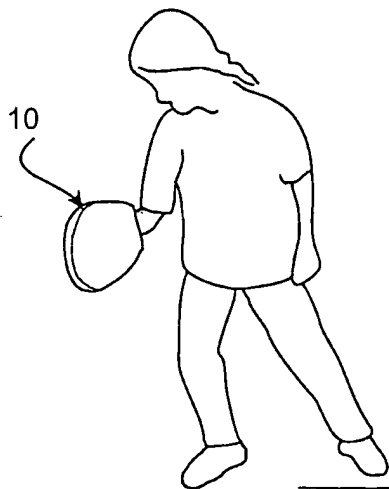
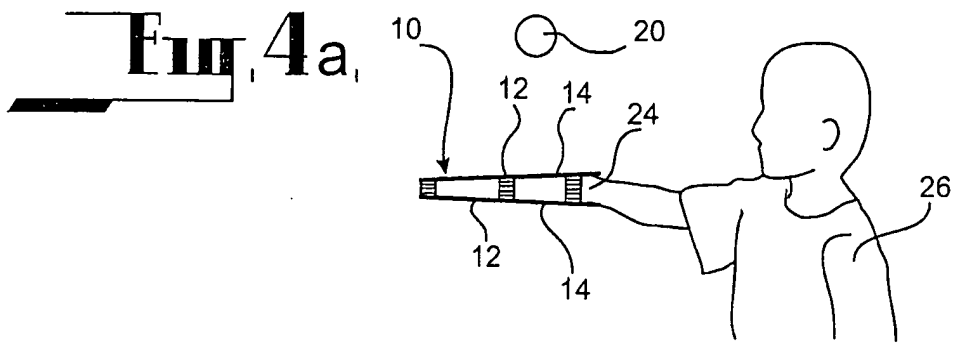
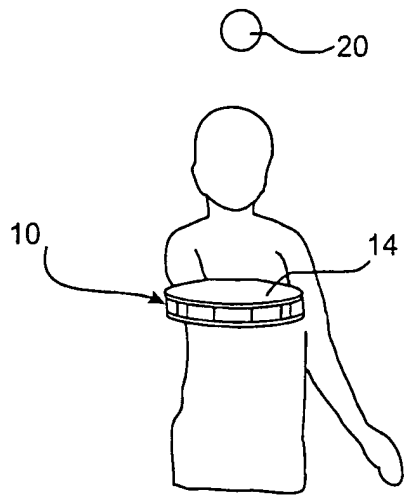

Fig. 4a,

Fig. 4b,

Fig. 4c,

Fig. 4d,

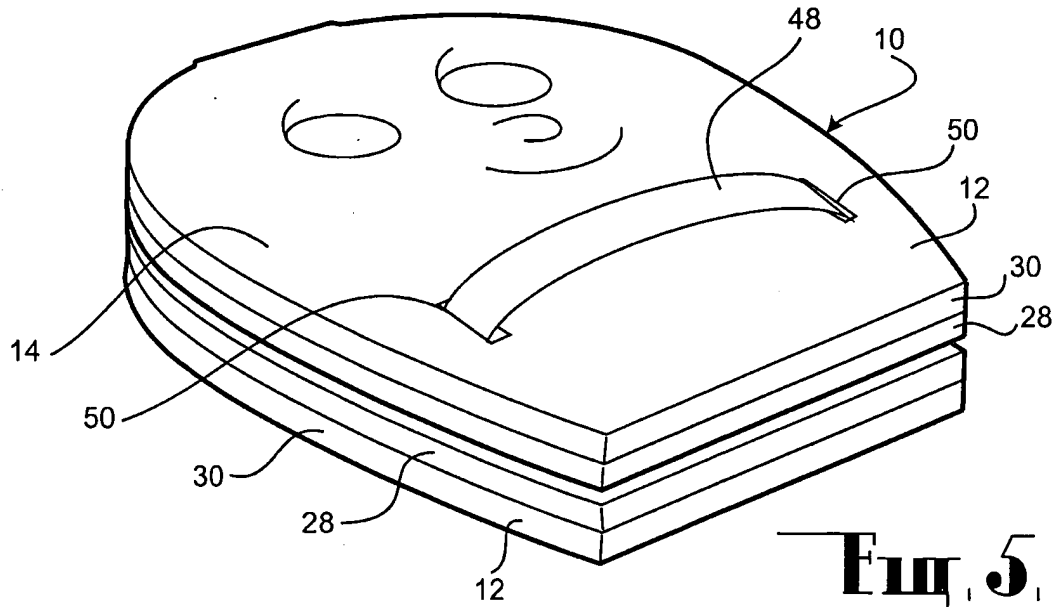

Fig. 5.

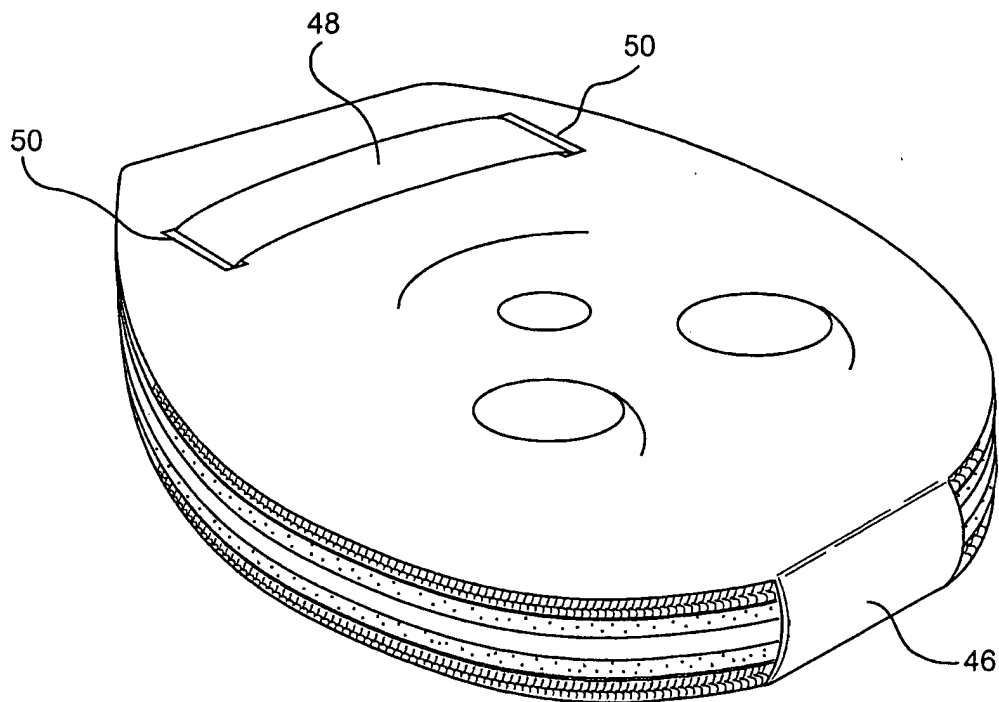

Fig. 6.

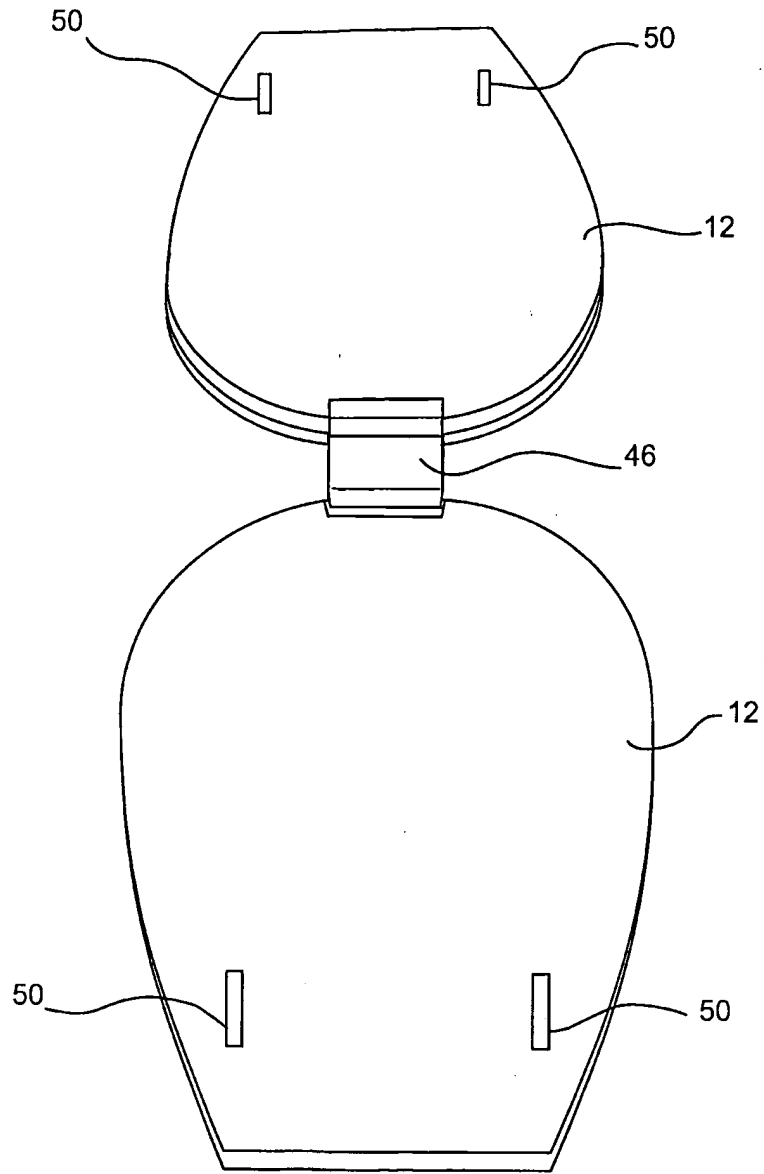
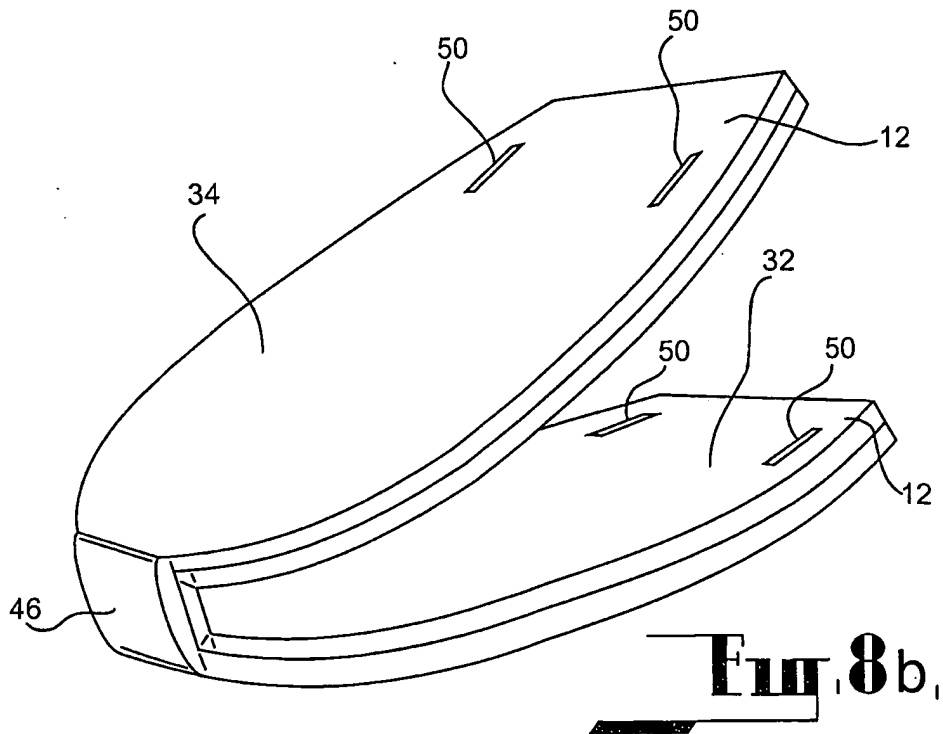
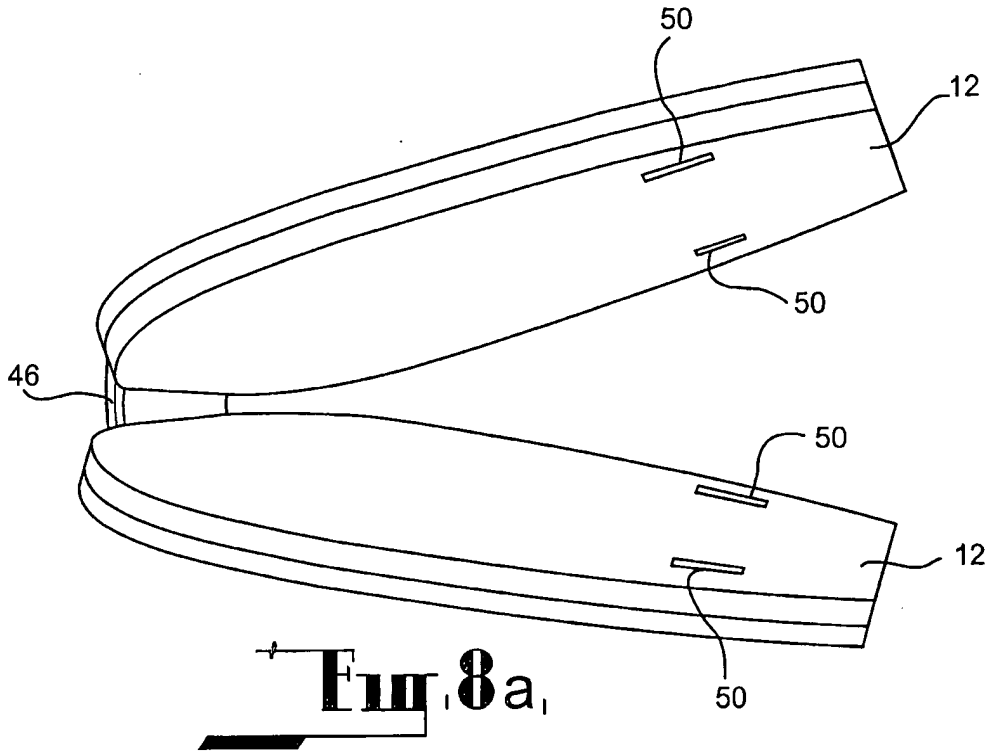

Fig. 7.



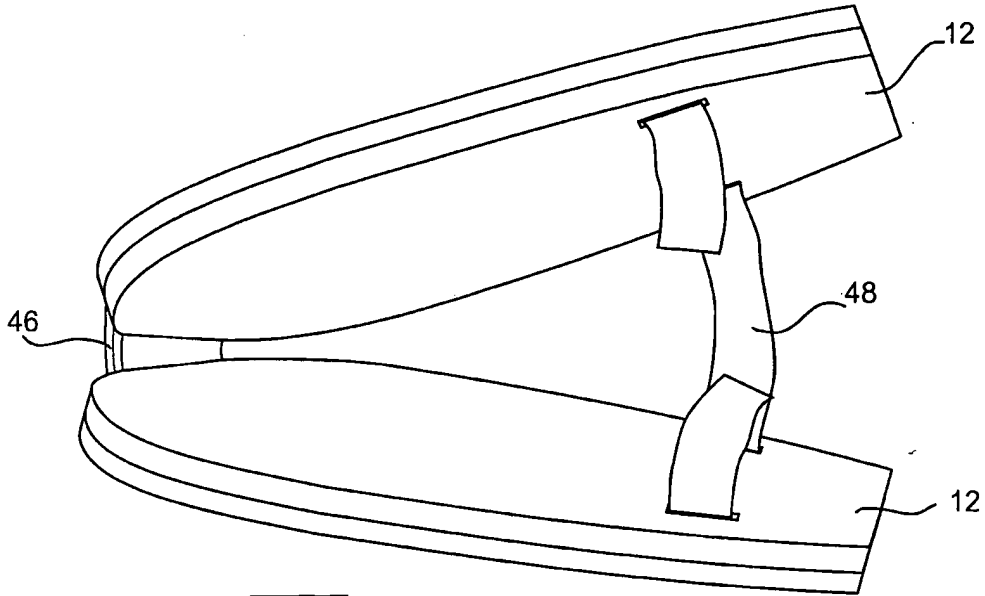

Fig. 9a,

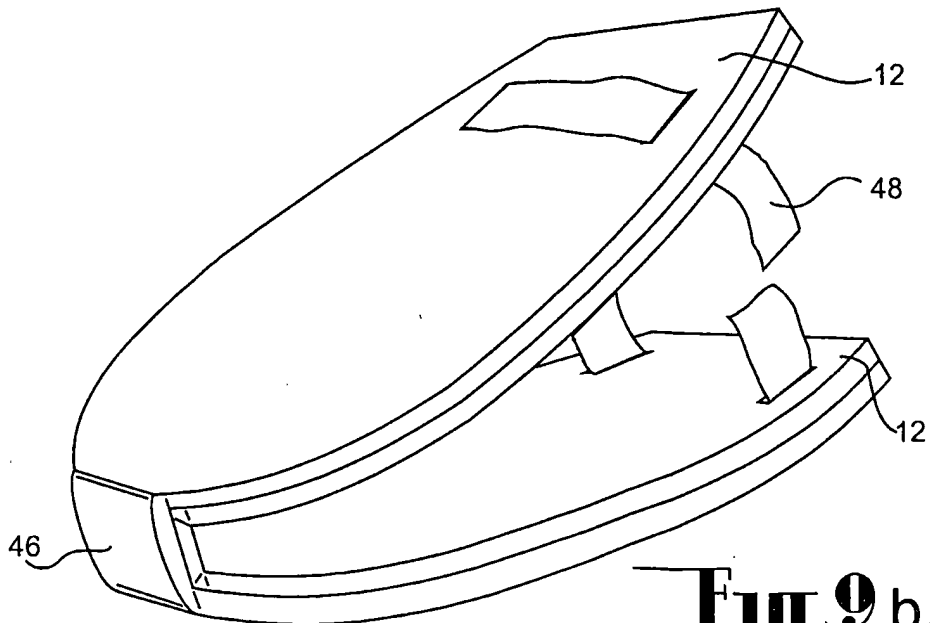

Fig. 9b,

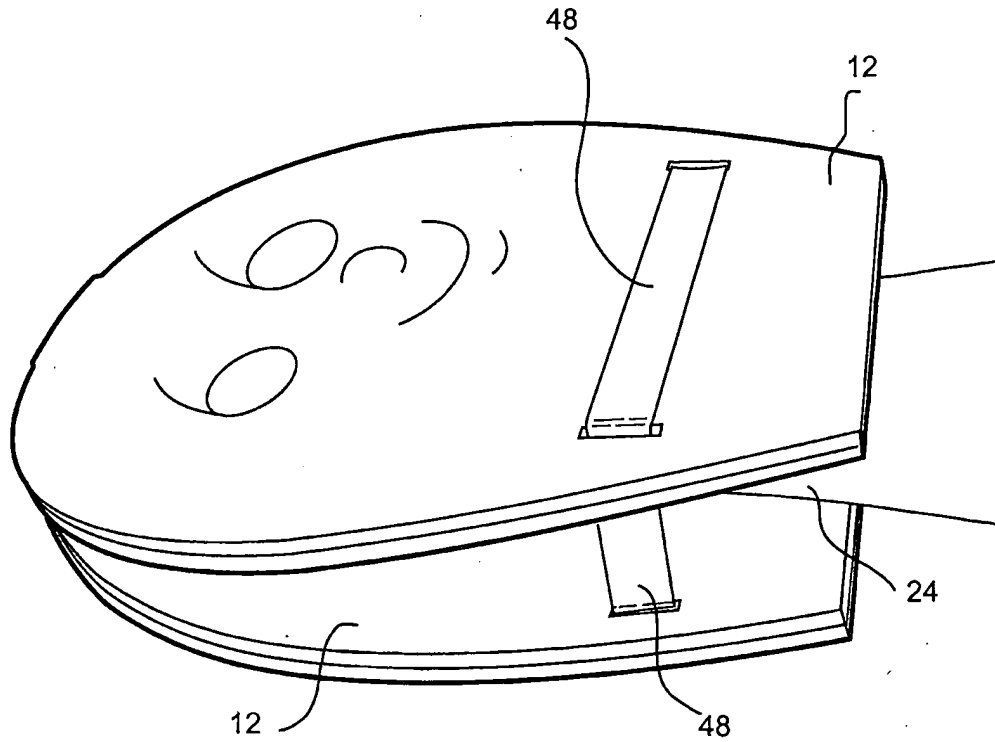

Fig. 10 a,

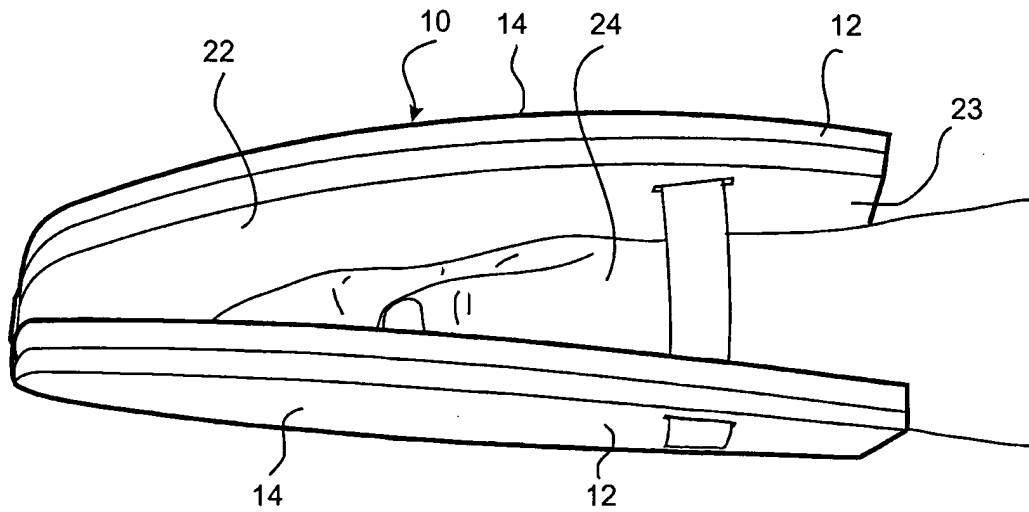

Fig. 10 b,

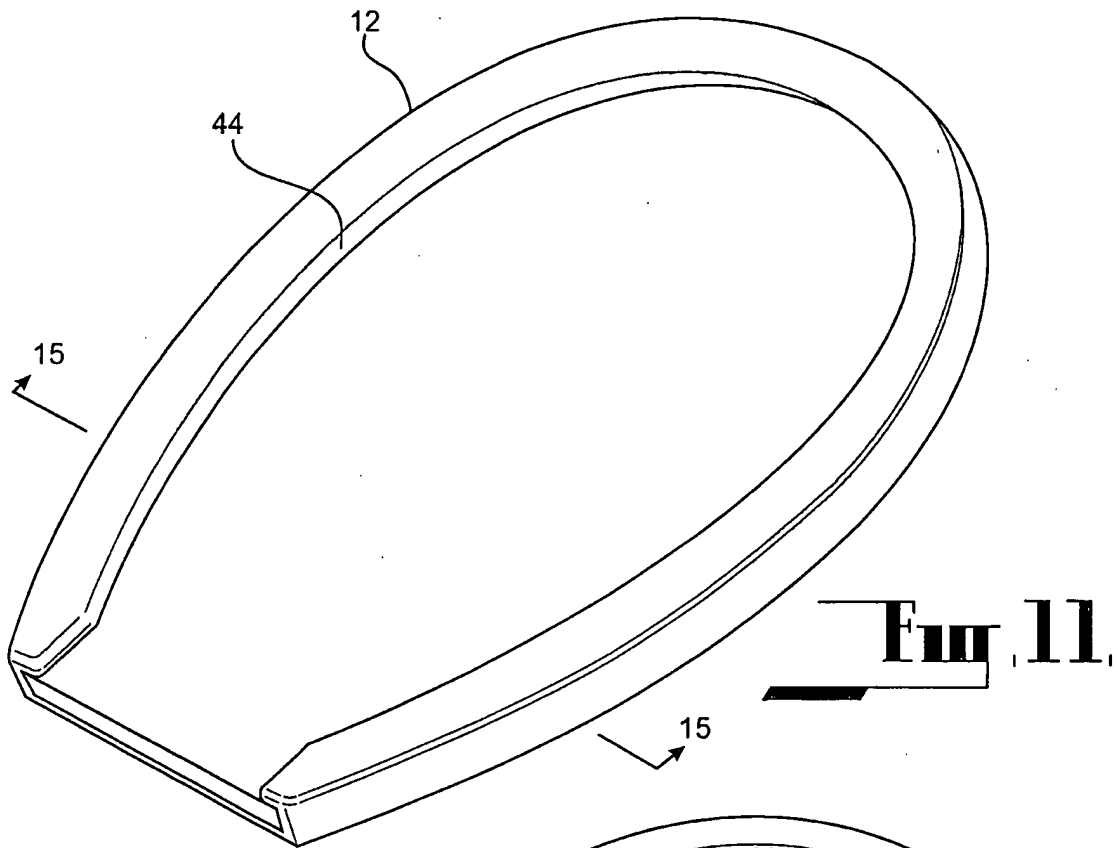

Fig. 11,

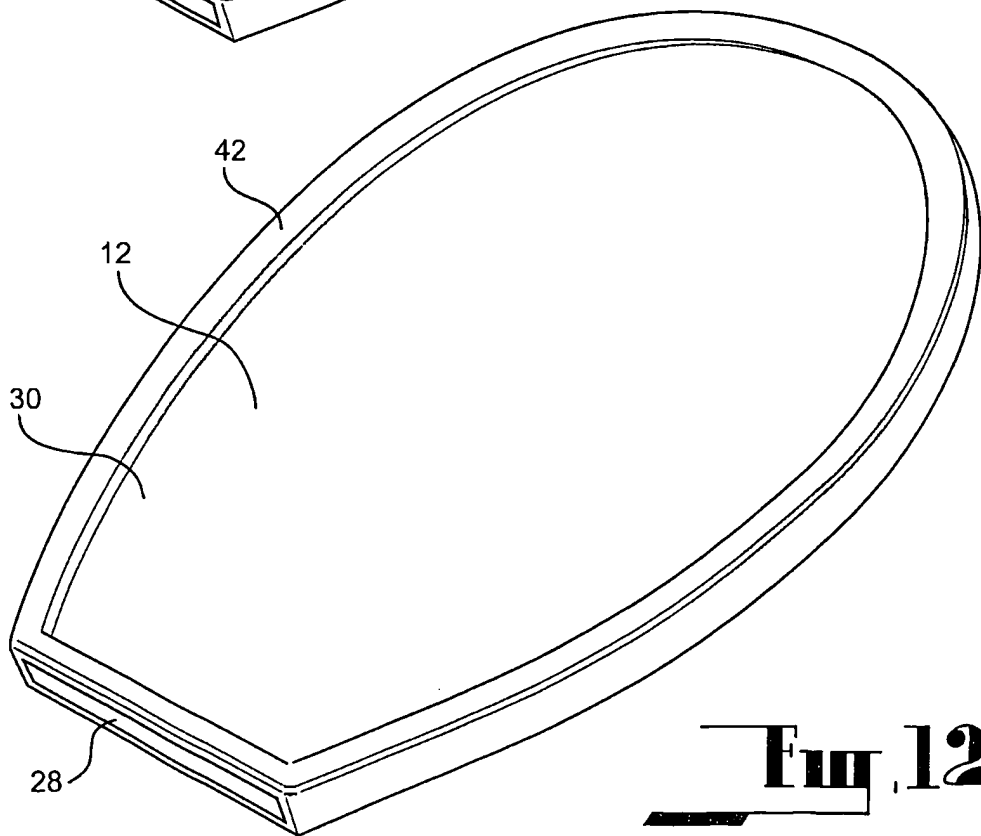

Fig. 12,

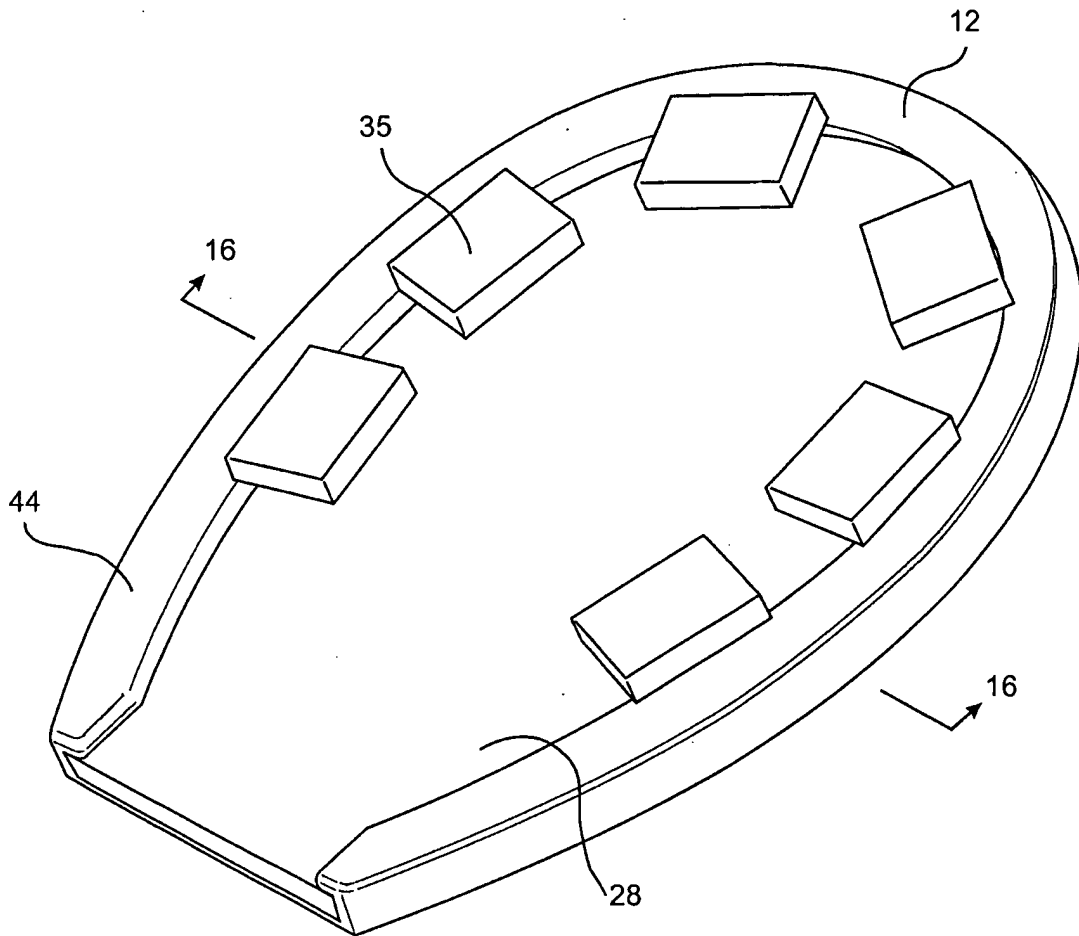

Fig. 13.

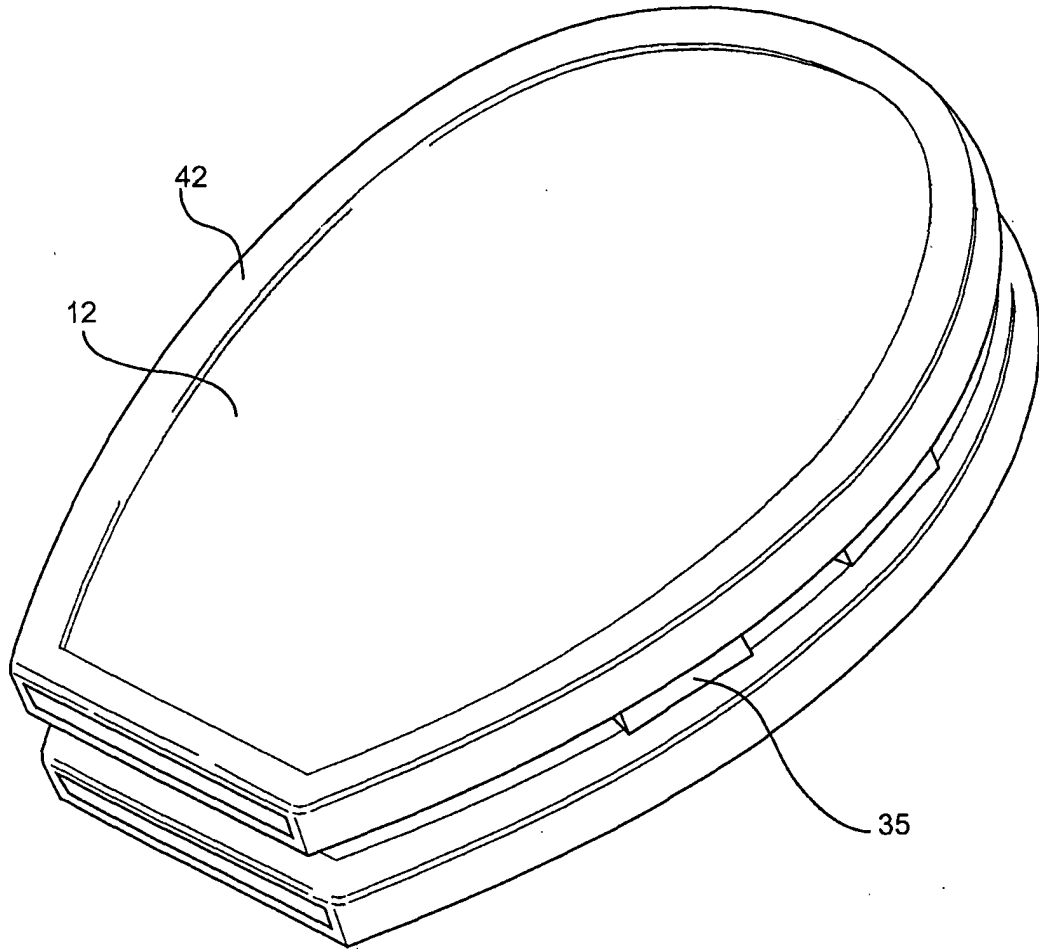

Fig. 14,

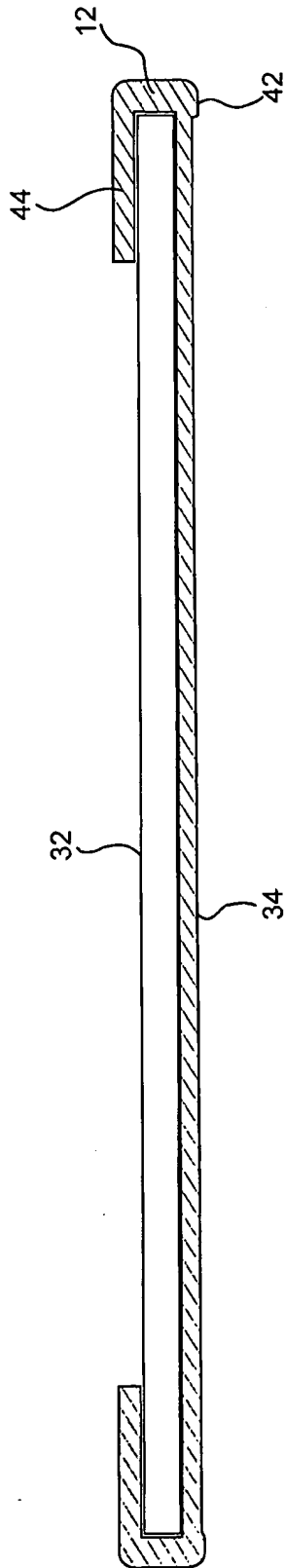

Fig. 15

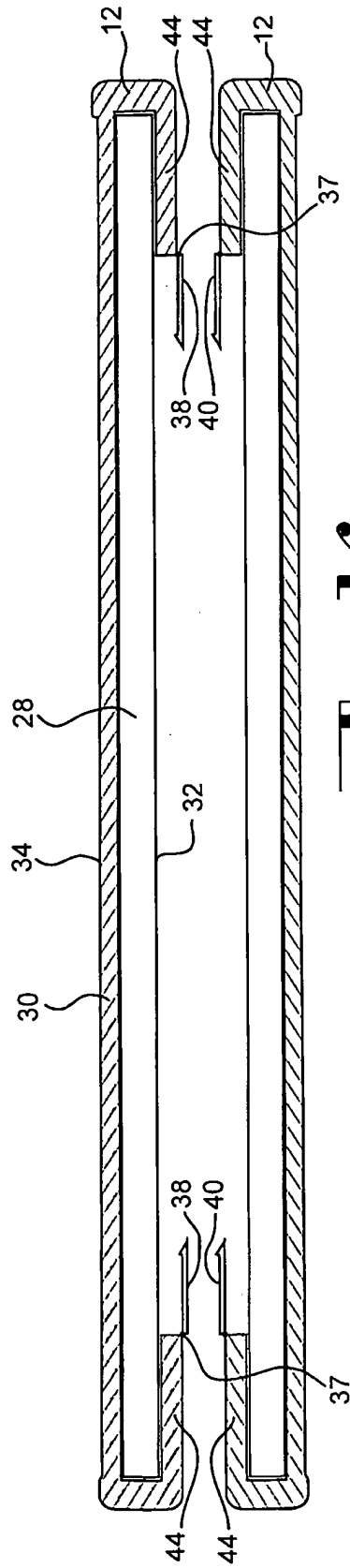

Fig. 16a,

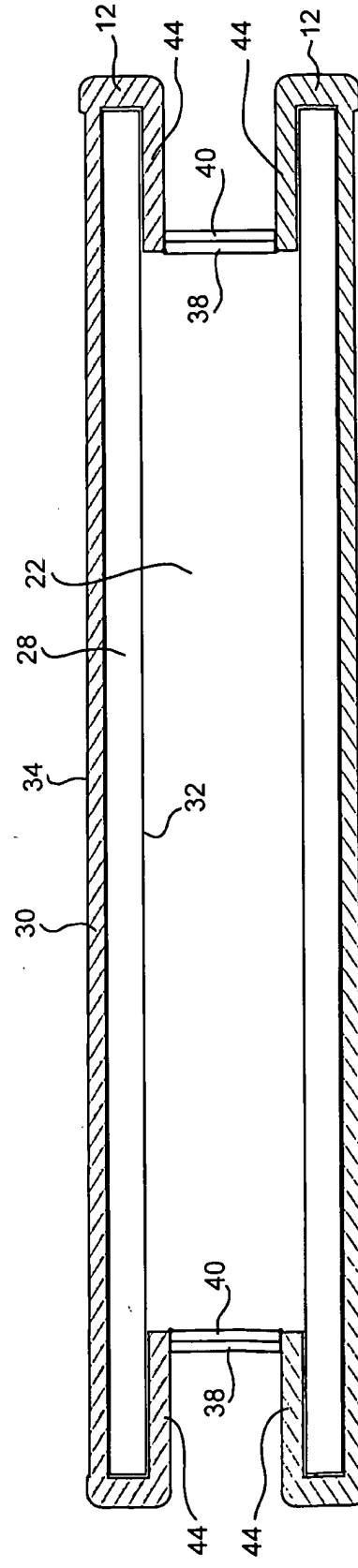

Fig. 16b,

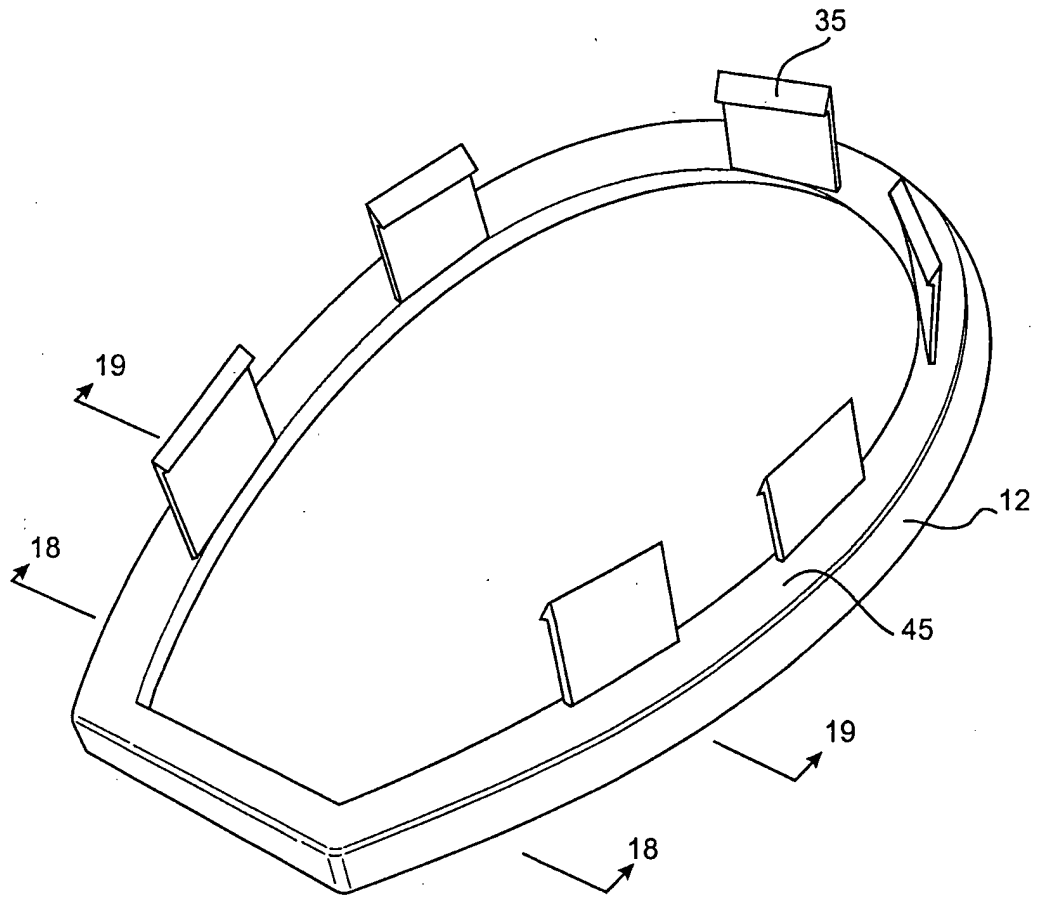

Fig. 17

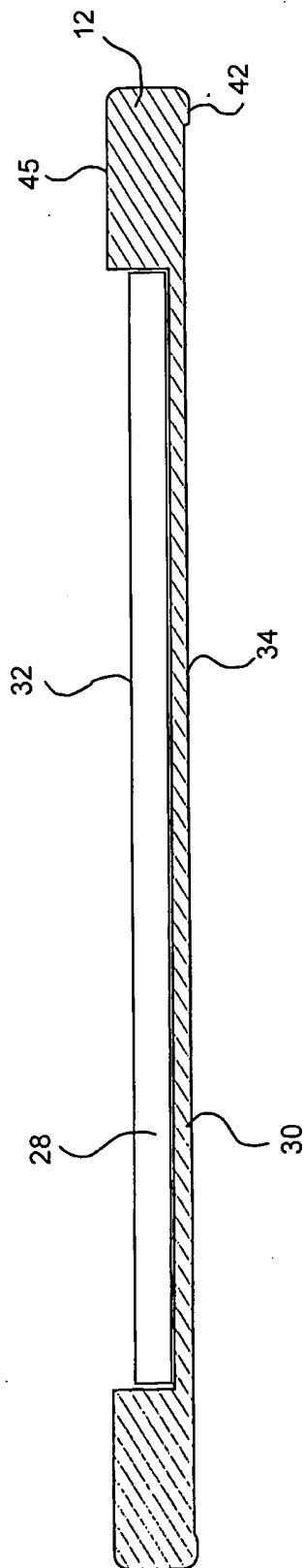

Fig. 18

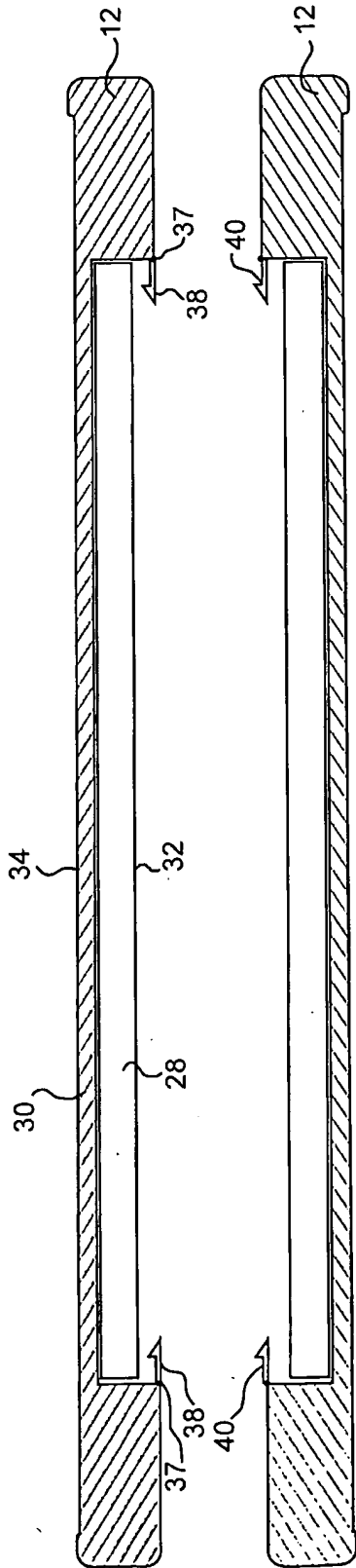

Fig. 19 a,

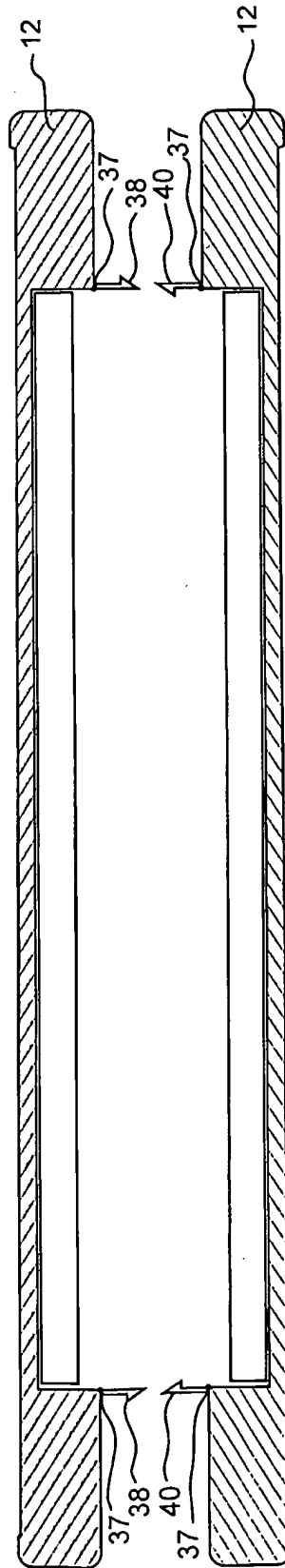

Fig. 19 b,

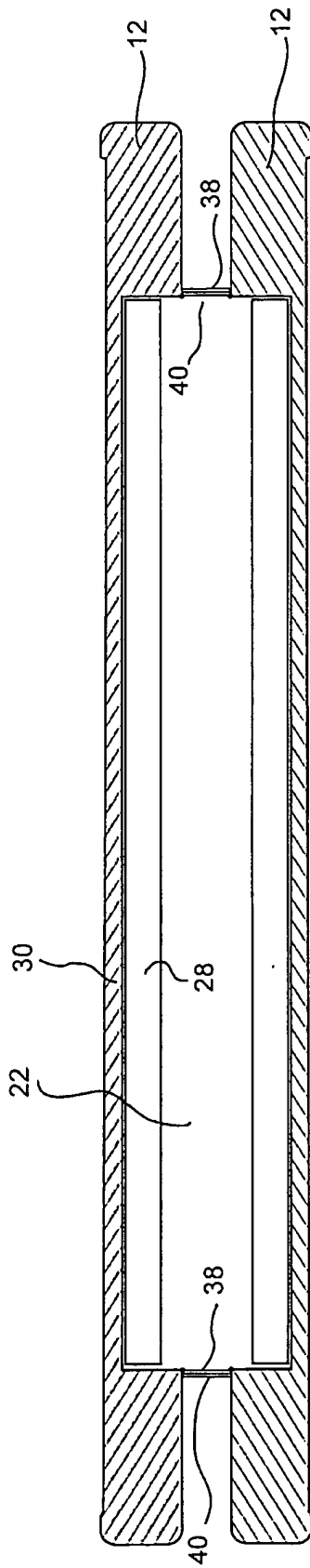

Fig. 20

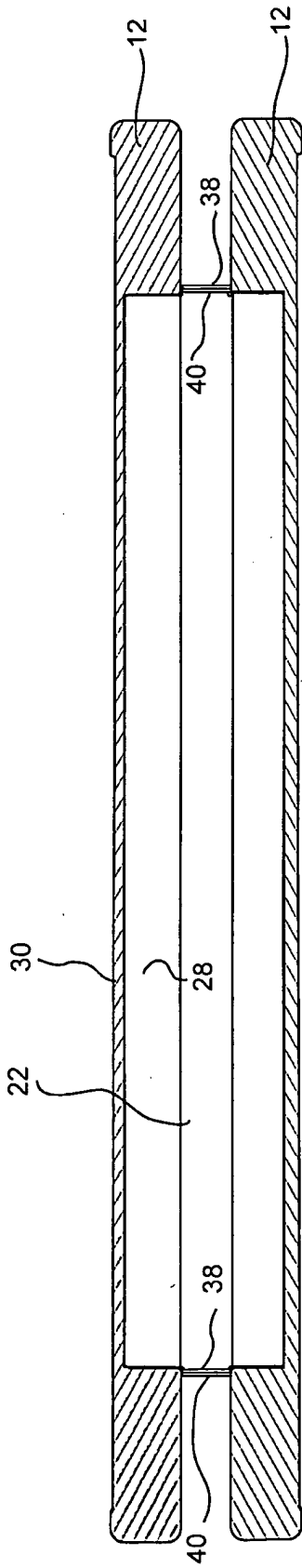

Fig. 21,

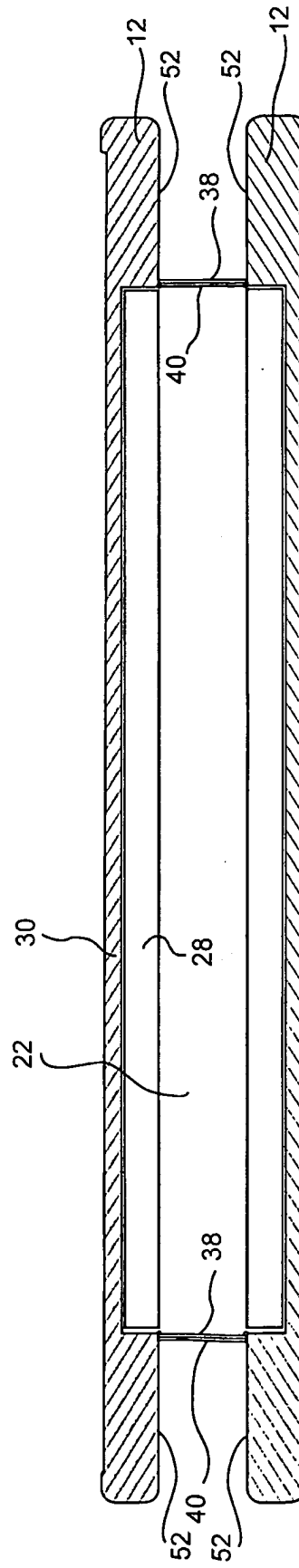

Fig. 22,

INTERNATIONAL SEARCH REPORT

International application No.

PCT/AU01/01386

A. CLASSIFICATION OF SUBJECT MATTER		
Int. Cl. ⁷ : A63B 59/00, A63B 71/14		
According to International Patent Classification (IPC) or to both national classification and IPC		
B. FIELDS SEARCHED		
Minimum documentation searched (classification system followed by classification symbols)		
Documentation searched other than minimum documentation to the extent that such documents are included in the fields searched		
Electronic data base consulted during the international search (name of data base and, where practicable, search terms used) DWPI: IPC A63B 49/-, A63B 59/00, 59/04, 59/06, 59/08, 59/18, A63B 67/-, A63B 69/-, A63B 71/14 and key words: {(wear, worn, receive, cover, glove, insert); (hand, palm, wrist, arm); (hit, strike, stroke, practice, bounce); (ball); (racket, racquet, bat, stick, club); (learn, train, coordinate, juggle, skill, exercise)} and like terms.		
C. DOCUMENTS CONSIDERED TO BE RELEVANT		
Category*	Citation of document, with indication, where appropriate, of the relevant passages	Relevant to claim No.
X	GB 2030871 A (BERTRAND CASTELLI) 16 April 1980 See entire document	1 - 33, 37 - 40
X	US 5549294 A (WELLEN ET AL) 27 August 1996 See entire document	1 - 33, 37 - 40
X	Derwent Abstract Accession No. 90-122179/16, Class P36, SU 1512638 A (KHARK RAIL TRANSP) 7 October 1989 See abstract and drawing	1 - 33, 37 - 40
<input type="checkbox"/> Further documents are listed in the continuation of Box C <input checked="" type="checkbox"/> See patent family annex		
* "A" "E" "L" "O" "P"	Special categories of cited documents: document defining the general state of the art which is not considered to be of particular relevance earlier application or patent but published on or after the international filing date document which may throw doubts on priority claim(s) or which is cited to establish the publication date of another citation or other special reason (as specified) document referring to an oral disclosure, use, exhibition or other means document published prior to the international filing date but later than the priority date claimed	"T" "X" "Y" "&" later document published after the international filing date or priority date and not in conflict with the application but cited to understand the principle or theory underlying the invention document of particular relevance; the claimed invention cannot be considered novel or cannot be considered to involve an inventive step when the document is taken alone document of particular relevance; the claimed invention cannot be considered to involve an inventive step when the document is combined with one or more other such documents, such combination being obvious to a person skilled in the art document member of the same patent family
Date of the actual completion of the international search 30 November 2001		Date of mailing of the international search report 6 DEC 2001
Name and mailing address of the ISA/AU AUSTRALIAN PATENT OFFICE PO BOX 200, WODEN ACT 2606, AUSTRALIA E-mail address: pct@ipaaustralia.gov.au Facsimile No. (02) 6285 3929		Authorized officer ABID ALI Telephone No : (02) 6283 2607

INTERNATIONAL SEARCH REPORT
Information on patent family members

International application No.
PCT/AU01/01386

This Annex lists the known "A" publication level patent family members relating to the patent documents cited in the above-mentioned international search report. The Australian Patent Office is in no way liable for these particulars which are merely given for the purpose of information.

Patent Document Cited in Search Report	Patent Family Member
GB 2030871	DE 2910082 FR 2437848 JP 55050375 US 4227692
US 5549294	NONE
SU 1512638	NONE

END OF ANNEX